

To Order Superquilt direct at Lowest prices in the UK or Europe
UK Customers Call 0844 9919949 From outside the UK Call 0044 1143230474

SuperQuilt

Multi-layer Insulation Blanket for *Floors*

Thermal Insulation in a thin, flexible, multi-layer membrane

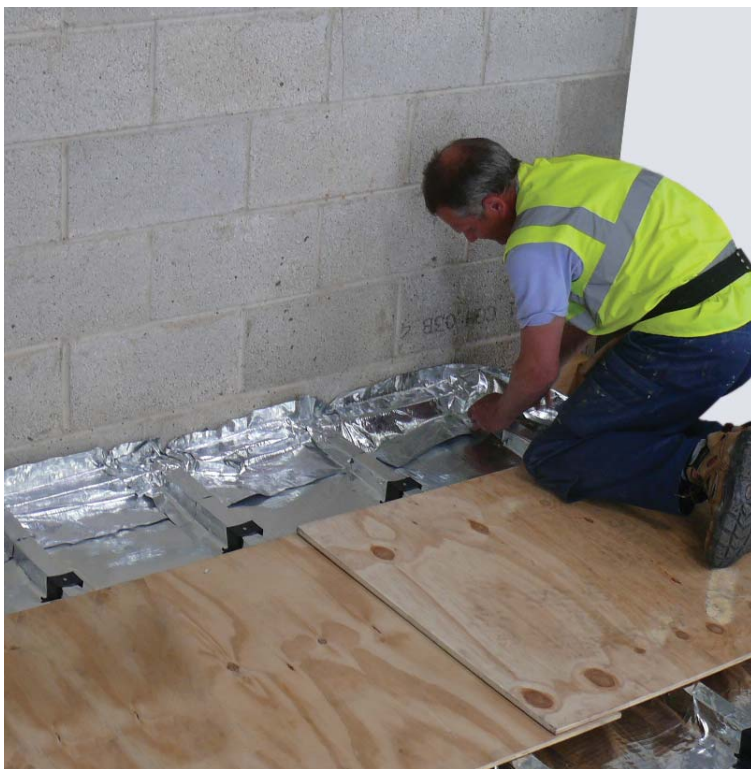

- For suspended & floating floors
- Fully certificated
- Hot box tested
- Meets requirements of BR443
- Core thermal resistance of 1.38m²K/W
- Class 1 Surface spread of flame
- Ideal for New build & Refurbishment
- Effective in summer and winter
- Lightweight, thin & flexible
- Fast and simple installation



BDA Agrément Nr.
BAR 09-346 • BAR 09-347
BAR 09-348



RD850111



194186

INSULATION FOR USE IN FLOORS

Benefits

- Fully certificated
- High core thermal resistance of 1.38m²K/W
- Effective in summer and winter
- Lightweight, thin & flexible
- Fast and simple installation
- Tear Resistant
- For suspended & floating floors

SuperQuilt is a very flexible, easy to fit, multilayer insulation that offers tremendous thermal benefits. Hot box testing confirms high core thermal resistance of 1.38m²K/W for SuperQuilt.

How does SuperQuilt Work?

Due to the special composition of multi-layers of insulation, SuperQuilt effectively deals with all forms of energy transfer (i.e. conduction, convection and radiation). SuperQuilt works most effectively by reflecting infra-red radiation.

General Fixing Instructions

Suspended Timber Floor

SuperQuilt is rolled out over the joists, then nailed in place through the YBS saddle clips to maintain the required 50mm airspace (4 saddle clips per m²).

The horizontal joints are tightly overlapped and left open to allow any moisture accumulation to dissipate.

SuperQuilt should be sealed around the perimeter or brought up above the floor deck.

The decking is then fixed at 200mm centres with screws 37mm into the joists.

Floating Timber Floor

SuperQuilt is rolled out onto the concrete floor leaving enough edge overlap to protrude above the floor deck.

Timber joists/battens are then laid on top of the SuperQuilt, spaced at centres to suit the particular flooring.

The deck is then fixed at 200mm centres with screws 37mm into the joists/battens.

Suspended Timber Floor Application

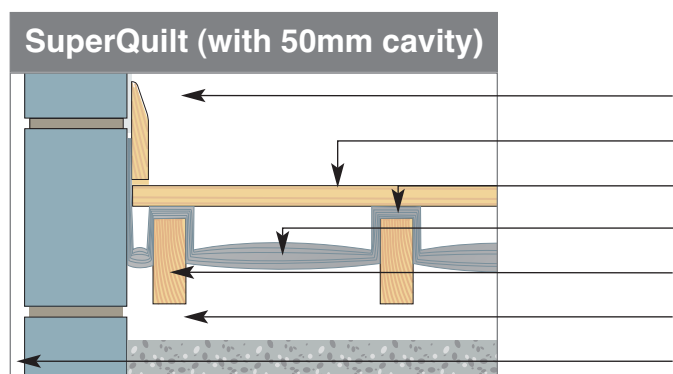

Construction	Thickness
Inside Surface	-
Chipboard Deck	22.00
Joist Cavity	50.00
SuperQuilt	40.00
Joist Cavity	100.00
Void	-
Outside Surface	-

P/A Ratio	U-Value (with 50mm Cavity above)	U-Value (with 100mm Cavity above)
0.1	0.15 W/m ² k	0.14 W/m ² k
0.2	0.19 W/m ² k	0.18 W/m ² k
0.3	0.21 W/m ² k	0.20 W/m ² k
0.4	0.23 W/m ² k	0.21 W/m ² k
0.5	0.24 W/m ² k	0.22 W/m ² k
0.6	0.24 W/m ² k	0.22 W/m ² k
0.7	0.25 W/m ² k	0.23 W/m ² k
0.8	0.25 W/m ² k	0.23 W/m ² k
0.9	0.26 W/m ² k	0.23 W/m ² k
1	0.26 W/m ² k	0.24 W/m ² k

Floating Timber Floor Application

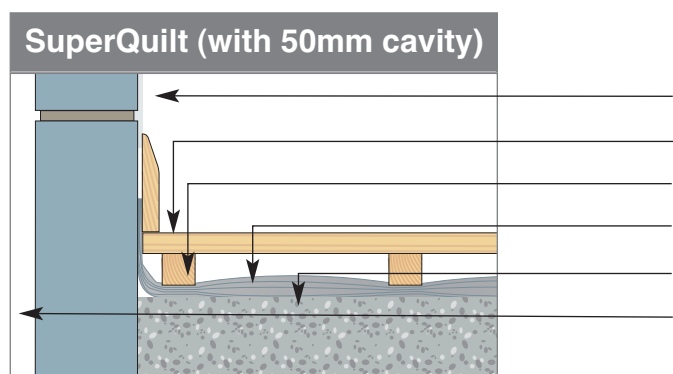

Construction	Thickness
Inside Surface	-
Chipboard Deck	22.00
Joist / Batten	50.00
SuperQuilt	40.00
Concrete Slabs	150.00
Outside Surface	-

P/A Ratio	U-Value (with 50mm Cavity above)	U-Value (with 100mm Cavity above)
0.1	0.13 W/m ² k	0.12 W/m ² k
0.2	0.20 W/m ² k	0.17 W/m ² k
0.3	0.24 W/m ² k	0.20 W/m ² k
0.4	0.26 W/m ² k	0.22 W/m ² k
0.5	0.28 W/m ² k	0.23 W/m ² k
0.6	0.30 W/m ² k	0.24 W/m ² k
0.7	0.31 W/m ² k	0.25 W/m ² k
0.8	0.32 W/m ² k	0.26 W/m ² k
0.9	0.33 W/m ² k	0.27 W/m ² k
1	0.34 W/m ² k	0.27 W/m ² k

Technical Properties

Product Description

19 Components

Thickness 40mm approx.

Weight 880g/m²

Mechanical Properties

Value

Reference Standard

Core thermal resistance 1.38m²K/W BS EN 12667

Flammability Class 1 BS 476-1

Class E BS EN 13501-1

Water vapour resistance 1569MNs/g BS EN 12572

Emission coefficients of surfaces 0.05 ASTM C 1371

Tensile strength 142KPA BS EN 1608

Packaging

15m²

10m²

Width 1.5m 1.5m

Length 10m 6.667m

Weight 13.5Kg 9Kg

P/A Ratio

The heat loss in a floor is greater at the exposed perimeter edge of the floor. To calculate the U-value, the exposed perimeter edge to area ratio needs to be worked out e.g. - a 100m² area, semi-detached house with 3 external walls of 10m each has a perimeter to area ratio 0.3 (i.e. 30m ÷ 100m² = 0.3).

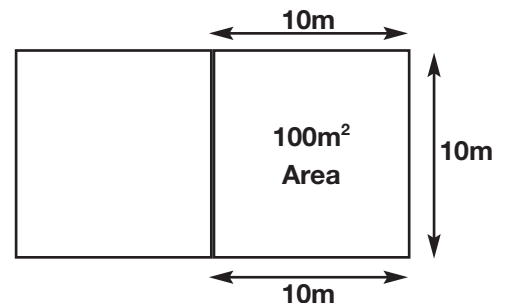

Cutting SuperQuilt

SuperQuilt can easily be cut using either a stanley knife or a good pair of scissors.



UK & European online supplier www.ecohome-insulation.com

UK Ordering 0844 9919949

European Ordering 0044 1143230474